

## Product Information Bulletin

64 Outwater Lane, Garfield, NJ 07026 Ph: 973-340-7889 | Fax: 973-340-7809

# 6ft Rubber Parking Block - R2700

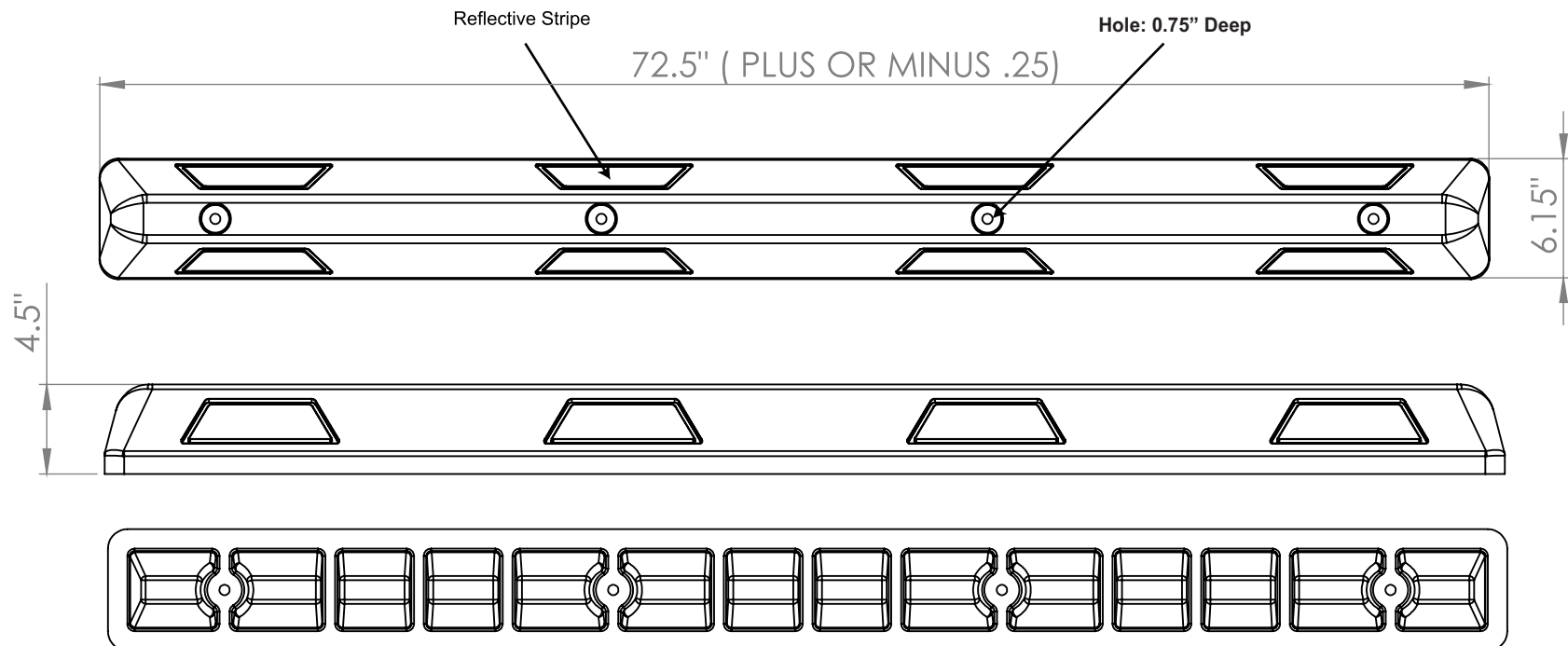

BOTTOM VIEW

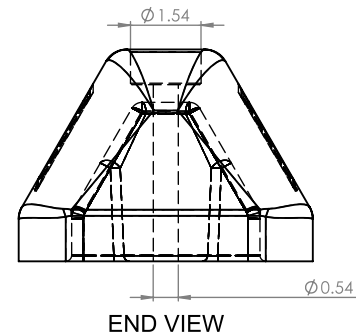

END VIEW

### NOTES:

1. WEIGHT: 35.5 lbs.
2. DIMENSIONS AND FEATURES ARE REPRESENTATIVE AND NOT GUARANTEED. FOR CRITICAL APPLICATIONS A SAMPLE OF CURRENT PRODUCTION PARTS SHOULD BE EVALUATED.